

Corrosion-proof and resistant to acids and salt

Lubrication nipples on all moving parts for long service life

Electric lift (AMX I15e)

Electro plated surfaces for straightforward cleaning

Robust and reliable



AMX I15/I15p/I15e/I15ep

Stainless steel scissor lift hand pallet truck (1,500 kg)

The Inox versions of the AMX I15 / I15e scissor lift hand pallet trucks are ideal for transporting goods in areas where absolute hygiene is required. The advantages of the stainless steel range come to the fore in damp and harsh environments. Tailored to the application at hand, it is possible to choose from

a number of different versions. Our decades of experience in stainless steel hand pallet trucks are reflected today in completely reliable and robust trucks. In meat or fish processing, the chemical or pharmaceuticals sectors, scissor lift hand pallet trucks offer the right solution.

AMX I15/I15p/I15e/I15ep

AMX I15/ I15p

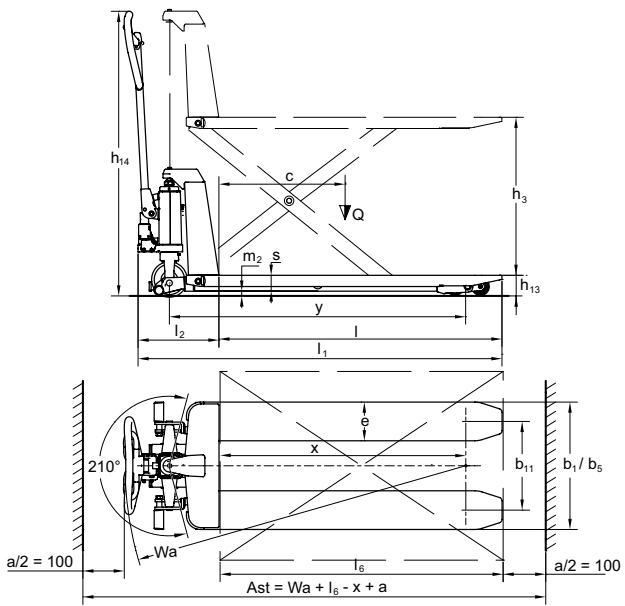

AMX I15p/ I15e/ I15ep

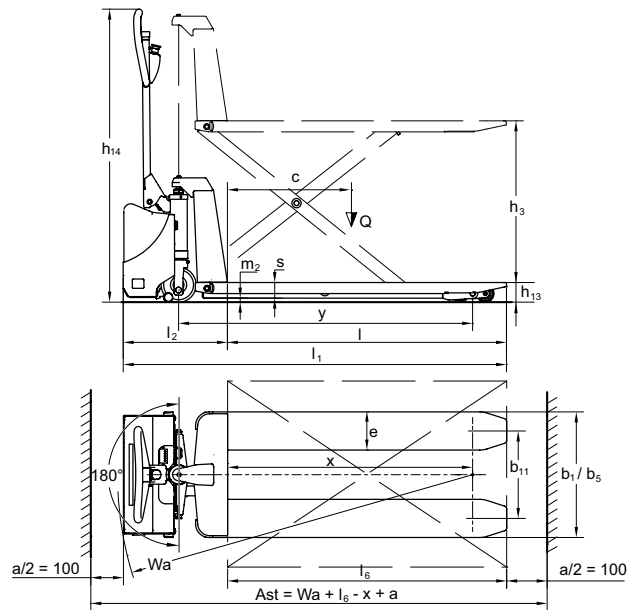

AMX I15/I15e

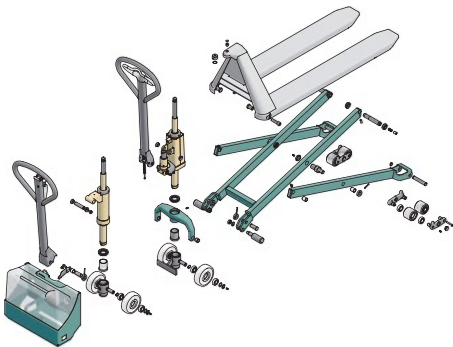

Left tiller figure is for the E model

- Electro plating
- Chromite coating
- Stainless steel (AISI 303/304)
- Acid resistant stainless steel (AISI 316)

AMX I15p/I15ep

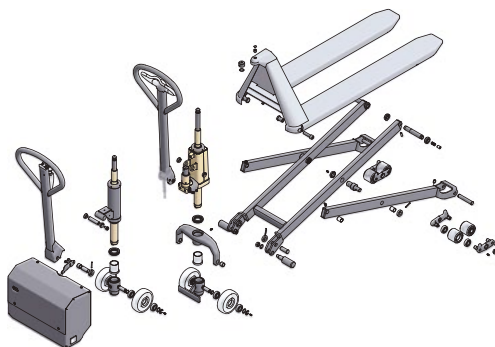

Left tiller figure is for the E model

Technical data in line with VDI 2198

			Jungheinrich						
			AMX I15	AMX I15p	AMX I15e	AMX I15ep			
Identification	1.1	Manufacturer (short form)							
	1.2	Model							
	1.3	Drive	manual	manual	Electrics	Electrics			
	1.4	Manual, pedestrian, stand-on, seated, order picker operation			hand				
	1.5	Load capacity/rated load	Q	t	1,5 ¹⁾				
	1.6	Load centre distance	c	mm	600				
	1.8	Load distance	x	mm	1,050				
	1.9	Wheelbase	y	mm	1,255				
	Weights	2.1	Service weight		kg	125	125	132	132
2.2		Axle load, w. load, front / rear		kg	720 / 358	750 / 358	753 / 357	753 / 387	
2.3		Axle load, w.o. load, front / rear		kg	38 / 70	38 / 70	40 / 100	40 / 100	
Wheels / chassis	3.1	Tyres			N,V				
	3.2	Tyre size, at front		mm	Ø 150x45				
	3.3	Tyre size, at rear		mm	Ø 75x68				
	3.5	Wheels, number front/rear (x = driven wheels)			2/4				
	3.6	Track width, front	b ₁₀	mm	145				
	3.7	Track width, rear	b ₁₁	mm	440				
	Basic dimensions	4.4	Lift		h ₃	mm	710		
4.9		Height of tiller in drive position min. / max.		h ₁₄	mm	1,230	1,230	1,270	1,270
4.15		Lowered height		h ₁₃	mm	85			
4.19		Overall length		l ₁	mm	1,580	1,580	1,645	1,645
4.20		Length incl. back of forks		l ₂	mm	340	340	445	445
4.21		Total width		b ₁ /b ₂	mm	540			
4.22		Fork dimensions		s/e/l	mm	50 / 163 / 1,200			
4.25		Width over forks		b ₅	mm	540			
4.32		Floor clearance centre wheelbase		m ₂	mm	19			
4.33		Aisle width for pallets 1000 x 1200 sideways	Ast	mm	1,630	1,630	1,690	1,690	
4.34		Aisle width for pallets 800 x 1200 lengthways	Ast	mm	1,830	1,830	1,890	1,890	
4.35	Turning radius	W _a	mm	1,480	1,480	1,540	1,540		
Performance data	5.3	Lower speed, w. / w.o. load		m/s	0.15 / 0.09	0.15 / 0.09	0.07 / 0.05	0.07 / 0.05	
Electrics	6.4	Battery voltage/nominal capacity K5		V/Ah			12 / 65	12 / 65	
	6.5	Battery weight		kg	0	0	21	21	

¹⁾ From lift height 470 mm, 1 t capacity

Benefit from the advantages



AMX I15/I15p control handle



Enclosed fork tips



AMX I15e/I15ep control handle

Easy handling

- Smooth controls for both left and right-handed operators.
- Special lowering valve for sensitive, controlled load lowering.
- Short front end dimension (340 mm) ensures safe operation even in confined spaces.
- Improved stability combined with floor protection thanks to standard tandem rollers.

Optimum hygiene

- The enclosed fork tips ensure that no dirt sprays up from the fork rollers onto the load during travel.

- Freely accessible or fully enclosed cavities allow for effective cleaning with no "hiding places for bacteria".
- Grease nipples on critical moving parts.
- Food grade lubricant (class H1 and H2).

Lift height

Extra support legs offer high stability up to a height of 800 mm.

Effortless lifting and lowering

- Option of manual hydraulic (AMX I15) or electro-hydraulic (AMX I15e) with 1.2 kW lift motor.
- Integrated pump unit with reservoir.

- Sensitive lowering with hand lever. The lowering valve is incorporated in the pump unit. The hydraulic system is protected against overloading by a pressure relief valve.

Forks

Robust, torsion-resistant construction with closed fork tips.

Maintenance-free battery and built-in charger (AMX I15e)

Built-in electronically controlled battery charger. Charging possible at any 240-V mains socket. Maintenance-free 65 Ah battery.

مجموعة الجذور
العربية



Roots Group
ARABIA

Earth Moving and Material Handling Equipment
Jeddah-Al-Nahda Dist-Prince Sultan Str.
Kingdom of Saudi Arabia
P.O. Box 52269 Jeddah 21563
Email kbahaa@arabian-roots.com
Mob +966 590950582
Tel +966 126996628 Ext: 245
Fax +966 126221473

Jungheinrich Aktiengesellschaft

Am Stadtrand 35
D-22047 Hamburg
Telephone +49 40 6948-0
Telefax +49 40 6948-1777

info@jungheinrich.com
www.jungheinrich.com

The German production facilities in Norderstedt and Moosburg are certified. ISO 9001 ISO 14001

Jungheinrich fork lift trucks meet European safety requirements.



JUNGHEINRICH
Machines. Ideas. Solutions.