

Powerful and efficient with
3-phase AC drive motor

Extremely manoeuvrable
due to compact design

Maintenance-free gel battery
and integrated charger

Four mast heights available
(2.300 - 3.300 mm)



EJC M10 ZT

Electric stacker trucks (1,000 kg)

The EJC M10 ZT was specially developed for the internal transfer of lightweight goods. The 0.6-kW drive motor supports the transport of pallets and goods weighing up to 1000 kg over short distances.

The duplex mast, which is available in four different heights from 2300 to 3300 mm, makes the EJC M10 ZT ideal for occasional picking as well as the stacking of pallets. Advantageous for this is the low frame height of the EJC M10 ZT which ensures that even shorter operators have optimum visibility of

the fork tips. Its compact design and the short front-end length (L2) of just 535 mm also guarantee maximum manoeuvrability.

Thanks to the maintenance-free, powerful 3-phase AC motor, energy consumption is reduced and the best conditions are provided for rapid and cost-efficient goods throughput.

A gel battery used in conjunction with a built-in charger allows for flexible operation, without having to fill up the battery with water.

EJC M10 ZT

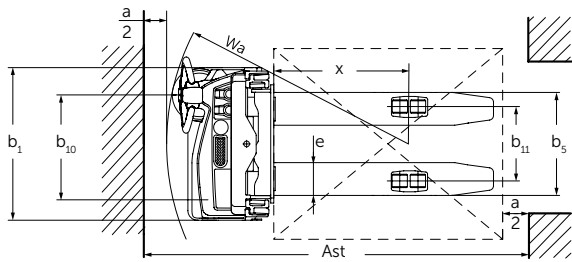
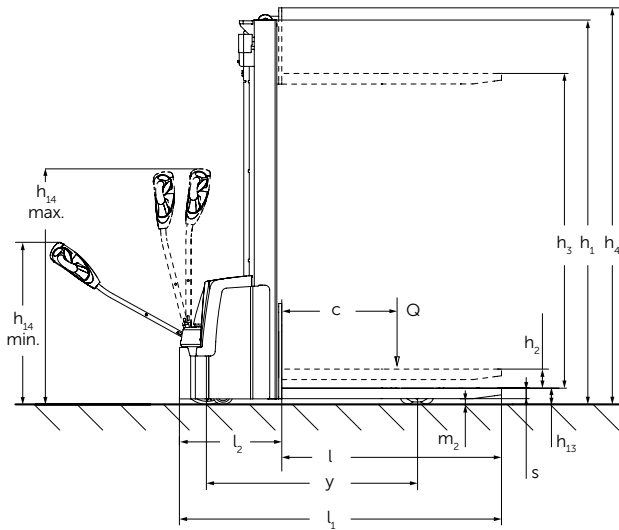

Technical data in line with VDI 2198

Identification	1.1	Manufacturer (abbreviation)		Jungheinrich			
	1.2	Model		EJC M10 ZT			
	1.3	Drive		Electric			
	1.4	Manual, pedestrian, stand-on, seated, order picker operation		pedestrian			
	1.5	Load capacity/rated load	Q t	1			
	1.6	Load centre distance	c mm	600			
	1.8	Load distance	x mm	710			
	1.9	Wheelbase	y mm	1,098			
	Weights	2.1.1	Net weight incl. battery (see row 6.5)	kg	589	598	616
2.2		Axle load with load front/rear	kg	536 / 1,098			
2.3		Axle load without load front/rear	kg	462 / 172			
Wheels / frame	3.1	Tyres		TPU/PU			
	3.2	Tyre size, front	mm	Ø230x65			
	3.3	Tyre size, rear	mm	Ø80x70			
	3.4	Additional wheels (dimensions)	mm	Ø100x50			
	3.5	Wheels, number front/rear (x = driven wheels)		1x+1/4			
	3.6	Tread width, front	b ₁₀ mm	550			
	3.7	Tread width, rear	b ₁₁ mm	390			
Basic dimensions	4.2	Mast height (lowered)	h ₁ mm	1,565	1,665	1,865	2,065
	4.3	Free lift	h ₂ mm	100			
	4.4	Lift	h ₃ mm	2,300	2,500	2,900	3,300
	4.5	Extended mast height	h ₄ mm	2,730	2,930	3,330	3,730
	4.9	Height of tiller in drive position min. / max.	h ₁₄ mm	740 / 1,190			
	4.15	Height, lowered	h ₁₃ mm	85			
	4.19	Overall length	l ₁ mm	1,685			
	4.20	Length to face of forks	l ₂ mm	535			
	4.21	Overall width	b ₁ /b ₂ mm	800 / 800			
	4.22	Fork dimensions	s/e/l mm	55 / 172 / 1,150			
	4.25	Width across forks	b ₅ mm	540			
	4.32	Ground clearance, centre of wheelbase	m ₂ mm	30			
	4.33	Aisle width for pallets 1000 × 1200 sideways	Ast mm	2,136			
4.34	Aisle width for pallets 800 × 1200 lengthways	Ast mm	2,103				
4.35	Turning radius	W _s mm	1,270				
Performance data	5.1	Travel speed, laden/unladen	km/h	4.5 / 5			
	5.2	Lift speed, laden/unladen	m/s	0.12 / 0.22			
	5.3	Lowering speed, laden/unladen	m/s	0.15 / 0.12			
	5.7	Gradeability laden/unladen	%	4 / 10			
	5.10	Service brake		electric			
Electrics	6.1	Drive motor, output S2 60 min.	kW	0.6			
	6.2	Lift motor kW power at S3 7.5 %	kW	2.2			
	6.3	Battery as per DIN 43531 /35/36 A, B, C, no		no			
	6.4	Battery voltage/ nominal capacity	V/Ah	24 / 105 ¹⁾			
	6.5	Battery weight	kg	52			
	6.6	Energy consumption according to VDI cycle	kWh/h	0.73			
Misc.	8.1	Type of drive control		AC SpeedControl			
	8.4	Sound pressure level at operator's ear as per EN 12053	dB (A)	66			

¹⁾ Specification battery voltage/nominal capacity at K20; at K5: 24V, 88Ah

Benefit from the advantages



Centralized control instruments



High level of safety due to low ground clearance



Ergonomic designed tiller head



Optimized visibility through mast

Innovative drive and control technology

Motors with 3-phase AC technology offer many advantages and more efficiency while simultaneously reducing the operating costs thanks to the perfect match with our own controllers:

- High efficiency levels with excellent energy management.
- Rapid directional change without delay.
- No carbon brushes - maintenance-free drive motor.

Energy-efficient operation

Economic energy management increases the efficiency and lifetime of the battery and components:

- Intelligent automatic shut-off: After 30 minutes without use, the truck automatically shuts off.
- Energy recovery due to regenerative braking when decelerating.

Compact design and ideal view

Thanks to its compact design, the EJC M10 ZT is perfect for use in confined spaces.

- High manoeuvrability due to short chassis length.
- Optimum visibility of the fork tips at any height thanks to low frame height and optimised visibility through mast.
- Important instruments such as battery discharge indicator, hourmeter, emergency disconnect and key are centrally located on the truck.
- Sufficient storage space even with slender design.

Ergonomic operations

The truck is perfectly adapted to the ergonomic needs of the operator:

- Reduced force required while steering due to low-mounted tiller.

- Dual-sided operation of tiller handle for ergonomic and safe use.

Safe operation

Various safety measures reduce the risk of injury for operators and guarantee a high level of safety:

- Reduced risk of foot injuries due to low ground clearance of only 30 mm.
- Additional protection due to completely closed frame and optimised visibility on the mast.

Options

The EJC M10 ZT with duplex mast is available in the lift heights 2,300 mm, 2,500 mm, 2,900 mm and 3,300 mm.



Earth Moving and Material Handling Equipment
Jeddah-Al-Nahda Dist-Prince Sultan Str.
Kingdom of Saudi Arabia
P.O. Box 52269 Jeddah 21563
Email kbahaa@arabian-roots.com
Mob +966 590950582
Tel +966 126998628 Ext: 245
Fax +966 126221473

Jungheinrich Aktiengesellschaft

Friedrich-Ebert-Damm 129
D-22047 Hamburg
Telephone +49 40 6948-0
Telefax +49 40 6948-1777

info@jungheinrich.com
www.jungheinrich.com

The German production facilities in Norderstedt, Moosburg and Landsberg are certified. **ISO 9001**
ISO 14001

Jungheinrich fork lift trucks meet European safety requirements.



JUNGHEINRICH
Machines. Ideas. Solutions.