

Cost-effective operation due to double-deck lorry loading

Sideways travel improves performance in applications with regular direction change

Narrow design and maximum manoeuvrability

High speed and acceleration improving productivity



ESD 120/220

Electric stand-on / sideways-seated stacker (2,000 kg)

The Jungheinrich ESD 120 / 220 range of fork lift trucks are highly flexible trucks. As double-deck fork lifts they can lift two Euro pallets simultaneously with both mast and support arm lift: Ideal for loading and unloading HGVs with two tiers. The ESD 120 / 220 can also be used as a conventional fork lift in the warehouse.

The width of the ESD 120 stand-on truck is only 760 mm, which is narrower than a Euro pallet. This allows for easy pallet positioning inside an HGV as well as for rapid loading and unloading. The fold-up seat offers additional comfort when travelling over longer distances. It acts as a comfortable backrest when folded up. The low entry height assists frequent entry and exit. The 820 mm wide ESD 220 is a pure sitdown truck, giving the operator maximum comfort. It is therefore particularly suited to

travelling over long distances. The adjustable foot-well height ensures a relaxed working position for all operators.

All trucks are fitted with powerful 24 V drive motors for rapid acceleration and high top speeds. The robust design also offers particular advantages: The frame and load sections are designed for capacities up to 2000 kg. Other advantages:

- Rapid travel speeds and acceleration.
- Extremely durable frame for exceptionally high operational demands.
- Display with steering position display and travel program selection (optional on the ESD 220).
- Electric steering for easy manoeuvring with a few turns of the steering wheel.
- Excellent energy management for low operating costs.

ESD 120/220

ESD 120

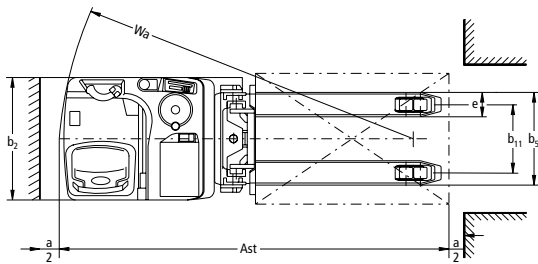
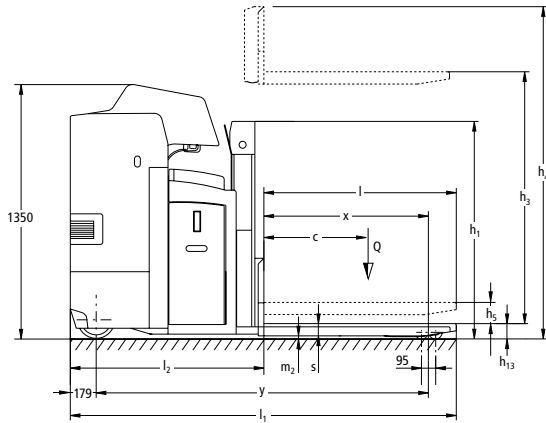

ESD 220

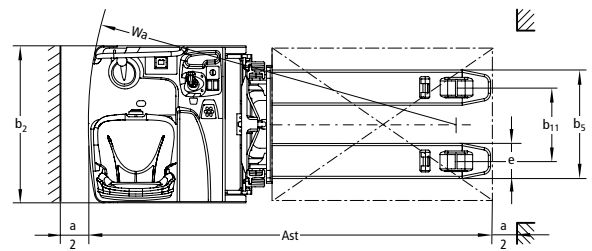
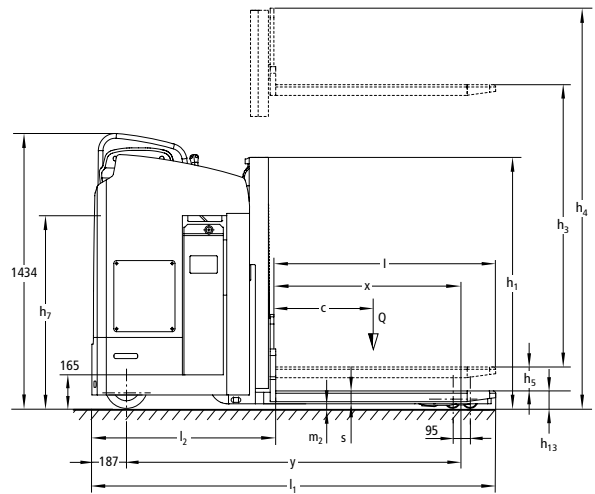

Technical data in line with VDI 2198

		Jungheinrich				
Identification	1.1	Manufacturer (abbreviation)				
	1.2	Model	ESD 120	ESD 220		
	1.3	Drive	Electric			
	1.4	Manual, pedestrian, stand-on, seated, order picker operation	stand/seat	seat		
	1.5	Load capacity/rated load	Q	t	2 ⁵⁾	
	1.5.1	Load capacity/mast lift	Q	t	1	
	1.5.2	Load capacity/support arm lift	Q	t	2	
	1.6	Load centre distance	c	mm	600	
	1.8	Load distance	x	mm	930 ⁴⁾	
1.9	Wheelbase	y	mm	1,835 / 1,905 ⁴⁾		
Weights	2.1.1	Net weight incl. battery (see row 6.5)	kg	1,258	1,350	
	2.2	Axle load with load front/rear	kg	1,220 / 2,038	1,340 / 2,010	
	2.3	Axle load without load front/rear	kg	884 / 374	982 / 368	
Wheels / frame	3.1	Tyres	Polyurethane		Vulkollan	
	3.2	Tyre size, front	mm	Ø 230 x 78	Ø 230 x 77	
	3.3	Tyre size, rear	mm	Ø 85 x 75	Ø 85 x 85	
	3.4	Additional wheels (dimensions)	mm	Ø 140 x 54		
	3.5	Wheels, number front/rear (x = driven wheels)		1+1x/4	2-1x/4	
	3.6	Tread width, front	b ₁₀	mm	475	544
	3.7	Tread width, rear	b ₁₁	mm	380	
Basic dimensions	4.2	Mast height (lowered)	h ₁	mm	1,250	1,309
	4.4	Lift	h ₃	mm	1,660	
	4.5	Extended mast height	h ₄	mm	2,250	2,150
	4.6	Initial lift	h ₅	mm	105	110
	4.8	Seat height/stand height	h ₇	mm	0	950
	4.8.1	Standing height	h ₇	mm	245	0
	4.15	Height, lowered	h ₁₃	mm	90	
	4.19	Overall length	l ₁	mm	2,260	2,185
	4.19.1	total length (long)		mm	2,330	0
	4.20	Length to face of forks	l ₂	mm	1,070 / 1,140	995
	4.21	Overall width	b ₁ /b ₂	mm	760	820
	4.22	Fork dimensions	s/e/l	mm	65 / 190 / 1,190	65 / 185 / 1,190
	4.25	Width across forks	b ₅	mm	570	
4.32	Ground clearance, centre of wheelbase	m ₂	mm	20	25	
4.34	Aisle width for pallets 800 x 1200 lengthways	Ast	mm	2,485 / 2,555 ²⁾	2,399	
4.35	Turning radius	W _a	mm	2,015 / 2,085 ⁴⁾	1,925 ³⁾	
Performance data	5.1	Travel speed, laden/unladen	km/h	7.5 / 9.2	9.1 / 9.1	
	5.2	Lift speed, laden/unladen	m/s	0.14 / 0.22	0.2 / 0.39	
	5.3	Lowering speed, laden/unladen	m/s	0.23 / 0.17	0.47 / 0.47	
	5.8	Max. gradeability, laden/unladen	%	6 / 12	8 / 14	
	5.10	Service brake		electro-mechanical	electric	
Electrics	6.1	Drive motor, output S2 60 min.	kW	2.0	2.8	
	6.2	Lift motor, output at S3 15%	kW	2.2	3.0	
	6.3	Battery as per DIN 43531 /35/36 A, B, C, no		43535 B	no	
	6.4	Battery voltage/nominal capacity K5	V/Ah	24 / 375	24 / 465	
	6.5	Battery weight	kg	288	380	
Misc.	8.1	Type of drive control		speedCONTROL	AC speedCONTROL	

¹⁾ Diagonal in accordance with VDI: + 211 mm

²⁾ Diagonal in accordance with VDI: + 213 mm

³⁾ Load section lowered: + 78 mm

⁴⁾ Load section raised / lowered: + 90 mm

⁵⁾ Mast lift capacity: max. 1 t

Benefit from the advantages



Grab handle for safe access and for the fitting of various options



ESD 120: Control panel for speed regulation and lift function



Activated initial lift



Comfortable seating position with height-adjustable footplate

Innovative 3-phase AC technology

Better performance simultaneously combined with reduced operating costs. Your advantages (for ESD 220):

- High level of efficiency with excellent energy management.
- Powerful acceleration.
- Rapid direction change.
- No carbon brushes – maintenance-free drive motor.
- Two-year warranty on the drive motor.

Productivity-enhancing ergonomics

The layout of the operators cab, which is sideways on to the travel direction ensures high visibility and reduces potential neck complaints. A safety switch in the foot well ensures maximum safety.

ESD 120

- Fold-up seat acts as a backrest when the driver is standing.
- Footrest for better support when seated.

ESD 220

- Comfort seat with weight adjustment.
- Padded armrest.
- Padded knee cushion.

Travel comfortably and safely

Safe speed regulation with SpeedControl, this ensures maximum safety and simple travel speed control in all situations.

- Roll-back protection on gradients with automatically activated brake.
- Constant travel speed on up and down gradients.
- Energy recovery with regenerative braking.
- Smooth, jerk free operation.

Flexible options

ESD 120

- Transport of two pallets simultaneously with double-deck load section.
- Rapid loading and unloading of HGVs.
- Easy pallet positioning directly on HGV side wall due to narrow truck width of 760 mm.
- Comfortable entry and exit due to low entry height.

ESD 220

- Drive and lift control via multifunction lever
- Comfortable seat makes it ideal for long distances.

- Easy manoeuvrability due to compact design.
- Ideal for block stacking.

Powerful battery

ESD 120

- Short battery compartment: 3 PzS 375 Ah.
 - Long battery compartment: 4 PzS 500 Ah.
 - Lateral battery exchange
- ### ESD 220
- 3 PzS 465 Ah.
 - Lateral battery exchange.

Options

- Different load wheels (depending on the application).
- Cold store version.
- Code lock.
- Steering wheel on the left (ESD 120).
- Load guard.
- Battery discharge indicator and steering position display (optional on the ESD 220).



Earth Moving and Material Handling Equipment
 Jeddah-Al-Nahda Dist-Prince Sultan Str.
 Kingdom of Saudi Arabia
 P.O. Box 52289 Jeddah 21583
 Email kbahaa@arabian-roots.com
 Mob +966 590950582
 Tel +966 126898628 Ext: 245
 Fax +966 126221473

The German production facilities in Norderstedt, Moosburg and Landsberg are certified. **ISO 9001**
ISO 14001

Jungheinrich fork lift trucks meet European safety requirements.



JUNGHEINRICH
 Machines. Ideas. Solutions.