

Quality engineering - Made in Germany: functional, robust and reliable

Jungheinrich drive axle and maintenance-free wet-disc brakes with electric parking brake

High visibility in all directions due to unique 'vision window' mast design

Truck design concept giving high productivity with low fuel consumption and high dynamic stability

Rugged Kubota industrial engines with high torque at low revs

4 point cushion mounted drive train giving a low-vibration operators cab area



DFG/TFG 425/430/435

Diesel and LPG forklifts with hydrodynamic drive (Torque Converter) (2,500/3,000/3,500 kg)

Our robust torque converter counterbalance trucks give you high productivity coupled with high reliability in all applications. The simple design of the torque converter drive train allows it to be used in a wide range of rugged and industrial operations; in addition it provides smooth power take up whilst accelerating, producing optimum efficiency at all speeds.

The rugged Kubota engines have been tried and tested throughout the world in harsh environments, including high and low temperatures, high humidity and tough terrains, returning optimum reliability.

Giving the strong benefit of lower fuel consumption and minimal noise. These robust engines are specifically designed for use in fork lift trucks. Giving you outstanding reliability and a long service life.

High levels of efficiency are delivered through the Jungheinrich

drive axle with integrated, maintenance free wet-disc brakes. Eliminating unnecessary costs associated with brake wear and lowering overall lifetime costs. The enclosed design of the braking system helps protect it by eliminating ingress of water or dust, which is typical in harsh conditions.

The operators cab is designed with the operator in mind. The visibility in all directions is class leading enhancing all round safety, resulting in a safe and productive driver maximising throughput throughout the shift.

Due to the unique Jungheinrich counterweight design, the centre of gravity is both low and centred between both front and rear the axles. This results in best in class dynamic stability and driving safety without unnecessary external electronic stability systems.

DFG/TFG 425/430/435

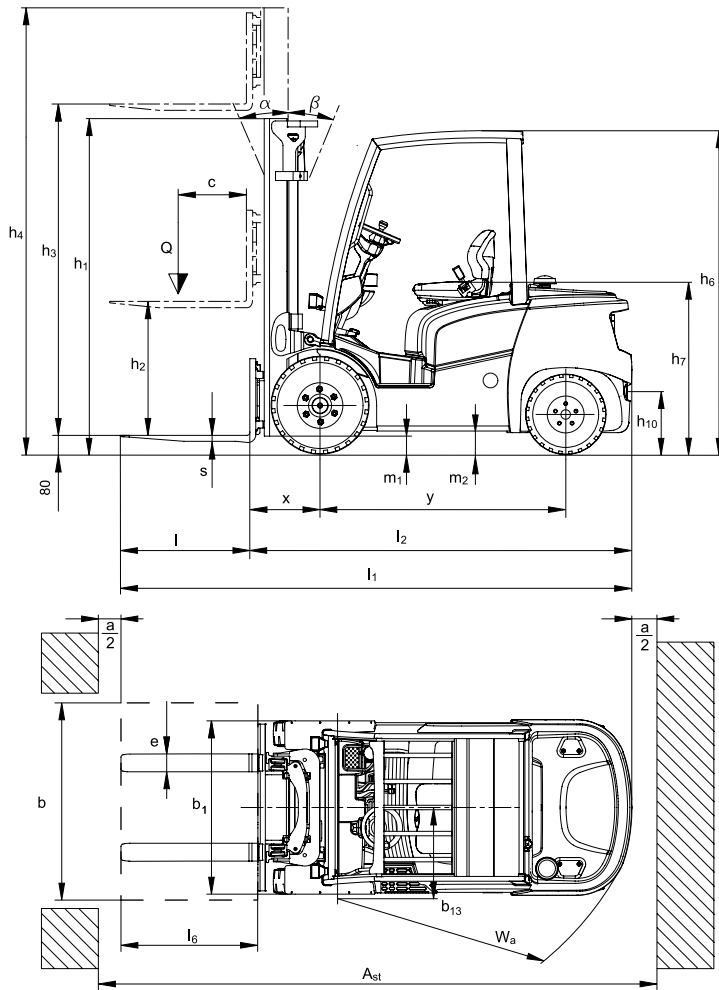

Capacity (kg)

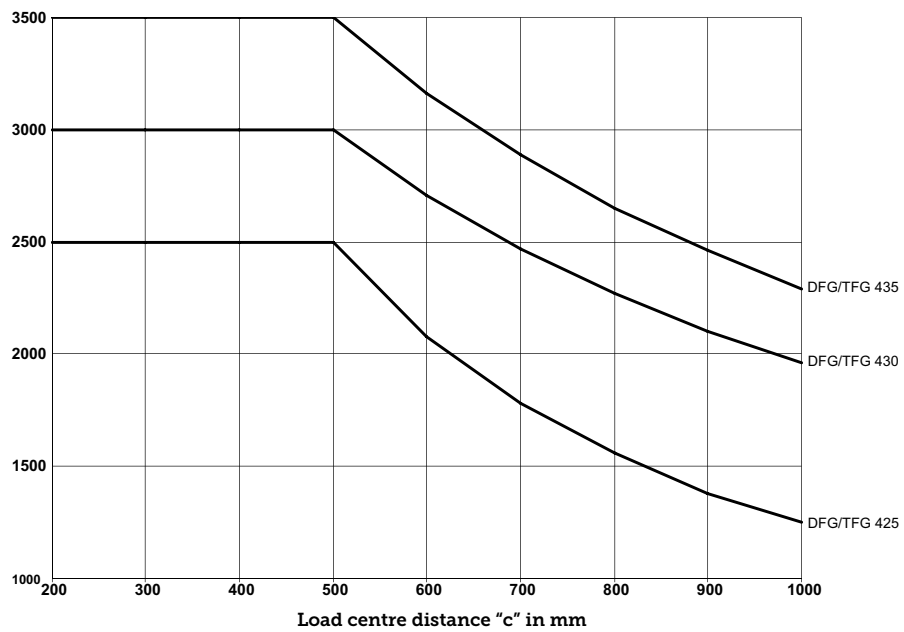

DFG/TFG 425/430/435

Standard mast designs DFG 425/DFG 430/DFG 435/TFG 425/TFG 430/TFG 435												
	Lift h_3 (mm)	Lowered mast height h_1 (mm)			Free lift h_2 (mm)			Extended mast height h_4 (mm)			Mast tilt forward / back α/β (°)	
		DFG 425 / TFG 425	DFG 430 / TFG 430	DFG 435 / TFG 435	DFG 425 / TFG 425	DFG 430 / TFG 430	DFG 435 / TFG 435	DFG 425 / TFG 425	DFG 430 / TFG 430	DFG 435 / TFG 435	DFG 425 / DFG 430 / TFG 425 / TFG 430	DFG 435 / TFG 435
		Duplex ZT	2900	2129	2122	2201	150	150	150	3502	3659	3689
	3100	2229	2222	2301	150	150	150	3702	3859	3889	6/8	6/8
	3300	2329	2322	2401	150	150	150	3902	4059	4089	6/8	6/8
	3500	2429	2422	2501	150	150	150	4102	4259	4289	6/8	6/8
	3700	2529	2522	2601	150	150	150	4302	4459	4489	6/8	6/8
	4000	2679	2672	2751	150	150	150	4602	4759	4789	6/8	6/8
	4300	2879	2872	2951	150	150	150	4902	5059	5089	6/8	6/8
	4500	2979	2972	3051	150	150	150	5102	5259	5289	6/8	6/6
	4700	3075	3075	3155	150	150	150	5350	5460	5490	6/6	6/6
	5000	3225	3225	3305	150	150	150	5650	5760	5790	6/6	6/6
	5500	3525	3525	3605	150	150	150	6200	6260	6290	6/6	6/6
	5800	3675	3675	3755	150	150	150	6500	6560	6590	6/6	6/6
	6000	3775	3775	3855	150	150	150	6700	6760	6790	6/6	6/6
Duplex ZZ	3100	2194	2187	2266	1614	1448	1497	3680	3839	3869	6/8	6/8
	3300	2294	2287	2366	1714	1548	1597	3880	4039	4069	6/8	6/8
	3500	2394	2387	2466	1814	1648	1697	4080	4239	4269	6/8	6/8
	3700	2494	2487	2566	1914	1748	1797	4280	4439	4469	6/8	6/8
	4000	2644	2637	2716	2064	1898	1947	4580	4739	4769	6/8	6/8
Triplex DZ	4400	2094	2087	2166	1514	1348	1397	4980	5139	5169	6/8	6/6
	4700	2194	2187	2266	1614	1448	1497	5280	5439	5469	6/6	6/6
	5000	2294	2287	2366	1714	1548	1597	5580	5739	5769	6/6	6/6
	5500	2494	2487	2566	1914	1748	1797	6080	6239	6269	6/6	6/6
	6000	2694	2687	2766	2114	1948	1997	6580	6739	6769	6/6	6/6
	6500	2894	2887	2966	2314	2148	2197	7080	7239	7269	6/6	6/6
	7000	3094	3087	3166	2514	2348	2397	7580	7739	7769	6/6	6/6
	7500	3294	3287	3366	2714	2548	2597	8080	8237	8269	6/6	6/6

Technical data in line with VDI 2198

			Jungheinrich			
			DFG 425	DFG 430	DFG 435	
Identification	1.1	Manufacturer (abbreviation)		Jungheinrich		
	1.2	Model		DFG 425	DFG 430	
	1.3	Drive		Diesel		
	1.4	Manual, pedestrian, stand-on, seated, order picker operation		seat		
	1.5	Load capacity/rated load	Q t	2.5	3	3.5
	1.6	Load centre distance	c mm	500		
	1.8	Load distance	x mm	472 ¹⁾	493 ²⁾	498 ²⁾
	1.9	Wheelbase	y mm	1,650	1,700	1,780
	Weights	2.1	Service weight	kg	3,660	4,190
2.2		Axle load with load front/rear	kg	5,480 / 680	6,390 / 800	7,170 / 900
2.3		Axle load without load front/rear	kg	1,510 / 2,150	1,640 / 2,550	1,710 / 2,860
Wheels / frame	3.1	Tyres		Pneumatic		
	3.2	Tyre size, front	mm	7.00-12	27x10-12	27x10-12
	3.3	Tyre size, rear	mm	6.00x9	6.50x10	6.50x10
	3.5	Wheels, number front/rear (x = driven wheels)		2x/2		
	3.6	Tread width, front	b ₁₀ mm	990	1,034	1,034
	3.7	Tread width, rear	b ₁₁ mm	940		
	Basic dimensions	4.1	Tilt of mast/fork carriage forward/backward	α/β °	6/8	
4.2		Mast height (lowered)	h ₁ mm	2,129	2,122	2,201
4.3		Free lift	h ₂ mm	150		
4.4		Lift	h ₃ mm	2,900		
4.5		Extended mast height	h ₄ mm	3,502	3,659	3,689
4.7		Height of overhead guard	h ₆ mm	2,175	2,180	2,180
4.8		Seat height/stand height	h ₇ mm	1,130	1,135	1,135
4.12		Coupling height	h ₁₀ mm	420	430	430
4.19		Overall length	l ₁ mm	3,617	3,768	3,863
4.20		Length to face of forks	l ₂ mm	2,567	2,718	2,813
4.21		Overall width	b ₁ /b ₂ mm	1,192	1,296	1,296
4.22		Fork dimensions	s/e/l mm	40 / 100 / 1,050	45 / 125 / 1,050	50 / 125 / 1,050
4.23		Fork carriage ISO 2328, class/type A, B		2A	3A	3A
4.24		Fork carriage width	b ₃ mm	1,120		
4.31		Floor clearance with load under mast	m ₁ mm	106	104	131
4.32		Ground clearance, centre of wheelbase	m ₂ mm	141	155	153
4.33		Aisle width for pallets 1000 x 1200 sideways	Ast mm	3,987	4,133	4,248
4.34	Aisle width for pallets 800 x 1200 lengthways	Ast mm	4,187	4,333	4,448	
4.35	Turning radius	W _a mm	2,315	2,440	2,550	
4.36	Smallest pivot point distance	b ₁₃ mm	720	730	750	
Performance data	5.1	Travel speed, laden/unladen	km/h	17 / 18		
	5.2	Lift speed, laden/unladen	m/s	0.55 / 0.57	0.58 / 0.6	0.48 / 0.5
	5.3	Lowering speed, laden/unladen	m/s	0.55 / 0.55		
	5.5	Drawbar pull w. / w.o. load	N	18,000		
	5.7	Gradeability laden/unladen	%	24 / 27	20 / 26	18 / 24
	5.9.2	Acceleration laden/unladen to 15 m	S	5.4 / 4.8	5.6 / 4.8	5.8 / 5
	5.10	Service brake		hydraulic		
5.11	Parking brake		hydraulic			
Combustion engine	7.1	Engine manufacturer / type		Kubota V2403-M-T		
	7.2	Engine output according to ISO 1585	kW	36.5		
	7.3	Rated revolutions per minute	/min	2,200		
	7.4	No. of cylinders		4		
	7.4.1	Cubic capacity	cm ³	2,434		
	7.5.1	Fuel consumption acc. to VDI cycle	l/h	3.2	3.7	3.9
Misc.	8.1	Type of drive control		hydrodynamic		
	8.2	Working pressure for attachments	bar	210		
	8.3	Oil flow for attachments	l/min	40		
	8.4	Sound pressure level at operator's ear as per EN 12053	dB (A)	82		
	8.5	Trailer coupling, model/type DIN		Bolt		
	8.6	Steering		hydraulic		

¹⁾ +12 mm with integrated sideshift

²⁾ +15 mm with integrated sideshift

Technical data in line with VDI 2198

			Jungheinrich			
			TFG 425	TFG 430	TFG 435	
Identification	1.1	Manufacturer (abbreviation)		Jungheinrich		
	1.2	Model		TFG 425	TFG 430	
	1.3	Drive		LPG		
	1.4	Manual, pedestrian, stand-on, seated, order picker operation		seat		
	1.5	Load capacity/rated load	Q t	2.5	3	3.5
	1.6	Load centre distance	c mm		500	
	1.8	Load distance	x mm	472 ¹⁾	493 ²⁾	498 ²⁾
	1.9	Wheelbase	y mm	1,650	1,700	1,780
	Weights	2.1	Service weight	kg	3,640	4,170
2.2		Axle load with load front/rear	kg	5,460 / 680	6,370 / 800	7,150 / 900
2.3		Axle load without load front/rear	kg	1,490 / 2,150	1,630 / 2,540	1,700 / 2,850
Wheels / frame	3.1	Tyres		Pneumatic		
	3.2	Tyre size, front	mm	7.00-12	27x10-12	27x10-12
	3.3	Tyre size, rear	mm	6.00x9	6.50x10	6.50x10
	3.5	Wheels, number front/rear (x = driven wheels)		2x/2		
	3.6	Tread width, front	b ₁₀ mm	990	1,034	1,034
	3.7	Tread width, rear	b ₁₁ mm		940	
	Basic dimensions	4.1	Tilt of mast/fork carriage forward/backward	α/β °		6/8
4.2		Mast height (lowered)	h ₁ mm	2,129	2,122	2,201
4.3		Free lift	h ₂ mm		150	
4.4		Lift	h ₃ mm		2,900	
4.5		Extended mast height	h ₄ mm	3,502	3,659	3,689
4.7		Height of overhead guard	h ₆ mm	2,175	2,180	2,180
4.8		Seat height/stand height	h ₇ mm	1,130	1,135	1,135
4.12		Coupling height	h ₁₀ mm	420	430	430
4.19		Overall length	l ₁ mm	3,617	3,768	3,863
4.20		Length to face of forks	l ₂ mm	2,567	2,718	2,813
4.21		Overall width	b ₁ /b ₂ mm	1,192	1,296	1,296
4.22		Fork dimensions	s/e/l mm	40 / 100 / 1,050	45 / 125 / 1,050	50 / 125 / 1,050
4.23		Fork carriage ISO 2328, class/type A, B		2A	3A	3A
4.24		Fork carriage width	b ₃ mm		1,120	
4.31		Floor clearance with load under mast	m ₁ mm	106	104	131
4.32		Ground clearance, centre of wheelbase	m ₂ mm	141	155	153
4.33		Aisle width for pallets 1000 x 1200 sideways	Ast mm	3,987	4,133	4,248
4.34		Aisle width for pallets 800 x 1200 lengthways	Ast mm	4,187	4,333	4,448
4.35	Turning radius	W _a mm	2,315	2,440	2,550	
4.36	Smallest pivot point distance	b ₁₃ mm	720	730	750	
Performance data	5.1	Travel speed, laden/unladen	km/h		18 / 19	
	5.2	Lift speed, laden/unladen	m/s	0.58 / 0.6	0.59 / 0.61	0.5 / 0.52
	5.3	Lowering speed, laden/unladen	m/s		0.55 / 0.55	
	5.5	Drawbar pull w. / w.o. load	N		17,000	
	5.7	Gradeability laden/unladen	%	23 / 27	20 / 26	17 / 24
	5.9.2	Acceleration laden/unladen to 15 m	S	5.7 / 5	6.2 / 5.4	6.5 / 5.6
	5.10	Service brake			hydraulic	
5.11	Parking brake			hydraulic		
Combustion engine	7.1	Engine manufacturer / type		Kubota WG2503-L		
	7.2	Engine output according to ISO 1585	kW	36.5		
	7.3	Rated revolutions per minute	/min	2,200		
	7.4	No. of cylinders		4		
	7.4.1	Cubic capacity	cm ³	2,491		
	7.5	Fuel consumption acc. to VDI cycle	kg/h	3.2	3.8	4.3
	Misc.	8.1	Type of drive control		hydrodynamic	
8.2		Working pressure for attachments	bar	210		
8.3		Oil flow for attachments	l/min	40		
8.4		Sound pressure level at operator's ear as per EN 12053	dB (A)	82		
8.5		Trailer coupling, model/type DIN		Bolt		
8.6		Steering		hydraulic		

¹⁾ +12 mm with integrated sideshift

²⁾ +15 mm with integrated sideshift

DFG/TFG 425/430/435



Standard delivery specification

- Operators cab entry handle on upright of overhead load guard. High visibility overhead load guard suitable, as standard, for containers.
- Hydraulic steering on demand with load sensing technology.
- Steering column with adjustable tilt.
- Travel direction lever mounted on steering column.
- Individual hydraulic levers on the operators dashboard.
- Instrumentation with glare-free display for hour meter and tank capacity. Indicator lights for: - engine oil pressure, coolant temperature, battery charge, parking brake, transmission oil temperature, brake fluid level, neutral display, low fuel level warning (diesel), electronic preheating (diesel) and water in the diesel filter.
- Acoustic warning for excess coolant temperature.
- MSG20 faux leather seat with automatic lap belt and mechanical suspension. Setting options: Fore and aft adjustment, backrest tilt and weight adjustment (up to 130 kg).
- Functional storage compartments suitable for everyday use including a drink holder.
- Anti-noise and vibration rubber floor mat.
- Standard automotive pedal layout.
- Wet maintenance-free disc brakes with electric parking brake and audible safety warning.
- Two front halogen spotlights and two brake/rear lights on rear counterweight.
- Hydraulic control valve incorporating load sensing technology.
- Full-flow hydraulic oil filtration with suction and return filtering for maximum oil purity.
- Heavy duty cyclonic air cleaner.
- Oil cooler for torque converter and transmission oil.
- Closed pressurised cooling system.
- Enclosed towbar on counterweight.
- Full length belly plate.

Benefit from the advantages

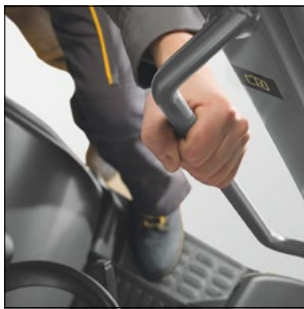

Entry via a deep, wide step. Large, strong grab handle welded to the overhead guard

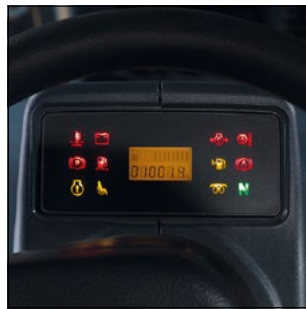

Display in the operator's field of vision



Automotive pedal configuration with non-slip surface



Optimum view of the load thanks to lift mast design giving ideal visibility

Powerful and efficient drive concept

- Tried and tested in harsh construction environments, industrial engines from Kubota in diesel and LPG models.
- Sturdy and modern engines. Designed for durability, high load capacity and reliability.
- High torque at low engine revs.
- Engine timing via inclined spurtoothed wheels.
- Engines with low emissions (diesel engines as per Directive 97/68/ EU stage 3A).

Ergonomic operator workstation

- The visibility in all directions is class leading enhancing all round safety.
- Entry via a deep, wide step. The step is clearly visible from the seated position.
- Large, strong grab handle welded to the overhead guard.
- Generous knee and legroom thanks to slim and easily adjustable steering column.
- Ergonomic steering wheel offset to the left.
- Effortless operation with hydraulic power assisted steering.
- Large, level footwell with vibration absorbing floor mat.
- Sturdy hydraulic levers positioned for easy use even when wearing gloves.
- Comfortable operators seat with excellent suspension and numerous adjustment options.
- Displays and switches for additional equipment (e.g. lighting and wipers) are positioned within the operator's reach and field of vision.
- Numerous storage options, such as drink holder, documents clip and a compartment for every day objects.
- Electrically applied parking brake, easily operated at the push of a button. Eliminating the usual knock on/knock off lever which restricts access in the knee and entry area.
- Automotive pedal layout with non-slip anti vibration surface.

Mast and hydraulics

- Smooth transitions provided by the mast cushioning system.
- High residual capacity at high lift heights.
- High visibility due to unique vision window.

- Flush face mast channels reducing the lost load centre.
- Hydraulic hoses routed for optimum visibility.
- Vision windows in the free lift cylinder cross-member, make it safer to work at higher racking levels.
- Hydraulic control valve incorporating load sensing technology. Due to the lower pressure level, the load sensing system reduces the energy consumption whilst keeping the unnecessary pumping losses to a minimum.

Jungheinrich drive axle with maintenance-free wet-disc brakes

- Axle concept with optimised efficiency for low fuel consumption.
- The oil immersed wet-disc braking system is maintenance-free. There are virtually no service costs (in comparison with conventional drum braking systems).
- No negative effect on braking due to environmental influences or service related downtime due to the enclosed design.

Uncoupled power train

Improved operator comfort and reduction of human vibrations to a minimum through:

- Floating drive unit.
- Drive shaft combination with universal joints.

Enclosed high-performance cooling system with combi cooler

- Heavy duty combi cooler in full aluminium design for engine coolant, converter and transmission oil – without the common plastic manifold which are susceptible to faults.
- Easy to clean with radiator cores of the cooling elements for engine coolant, converter and transmission oil.
- No coolant evaporation due to completely enclosed pressurised system.
- Reliable operation without a reduction in performance even at extreme ambient temperatures.

Easy to maintain and repair

- Optimum access to engine compartment due to 90° opening and L-shaped cover.

- Side sections and floor plate easily detachable without the need for tools.
- Minimal truck downtime thanks to simple, rapid and cost-effective maintenance – expert knowledge not required.
- Use of sturdy, high-quality components.
- No truck-specific diagnostic tools or special software required.
- Large fuel filter with water separator.
- Oil change interval 500 hours.

Reliable, heavy-duty electrical equipment

- Splash-proof electrics, plug and connections.
- Easily accessible at all times, compact fuse box on the operators console in the drivers compartment.

Jungheinrich high-mounted fully floating axle for high degree of passive safety

Even during dynamic travel, outstanding driving stability through reduced pendulum motion is guaranteed by the high pivot point of the steering axle. The risk of tip over is minimised by applying basic physics. Without the additional use of electronic assistance systems.

Optimised counterweight design

- The counterweight design displaces the centre of gravity downwards and forwards.
- The truck's centre of gravity is low and is situated between the front and rear axles.

Additional comfort equipment in different models (optional)

- Windscreen and rear window made of single-pane safety glass.
- Overhead roof panel made of laminated safety glass.
- Heated rear window (with vertical sliding window).
- Wipers and washer system for windscreen and rear window.
- Steel doors with sliding windows.
- Heating including windscreen demisters.
- Panoramic interior mirror.
- Left and right rear view mirrors.
- Armrest.

Benefit from the advantages



Simple, fast and affordable maintenance



Side sections are easily detachable without tools



Electrically applied parking brake, easily operated at the push of a button.



Heating including air demister for windscreen

- Comfort seats in fabric or synthetic leather.

Benefit from our safety and environmental benefits:

- Automatic hydraulic and travel interlock when the operator leaves the seat. All hydraulic functions and travel are only possible when the seat is occupied.
- Acoustic warning when the operator's seat is vacated, if the parking brake is not applied.
- Transmission is automatically placed into neutral as soon as operator leaves the truck.
- All diesel engines comply with the EU exhaust emissions stage 3A regulations.

مجموعة الجذور
العربية



Roots Group
ARABIA

Earth Moving and Material Handling Equipment
Jeddah-Al-Nahda Dist-Prince Sultan Str.
Kingdom of Saudi Arabia
P.O. Box 52289 Jeddah 21583
Email kbahaa@arabian-roots.com
Mob +966 590950582
Tel +966 126996628 Ext: 245
Fax +966 126221473

Jungheinrich Aktiengesellschaft

Friedrich-Ebert-Damm 129
D-22047 Hamburg
Telephone +49 40 6948-0
Telefax +49 40 6948-1777

info@jungheinrich.com
www.jungheinrich.com

The German production facilities in Norderstedt, Moosburg and Landsberg are certified. **ISO 9001**
ISO 14001

Jungheinrich fork lift trucks meet European safety requirements.



JUNGHEINRICH
Machines. Ideas. Solutions.